



IMCCA Class Rules



Class Rules of the Micro Class edition 2006-2009

revised December 2006, February 2008, May 2010

Note: by decision of the General Assembly,
the new edition of the Class Rules is due

to be published in 2013 instead of 2010

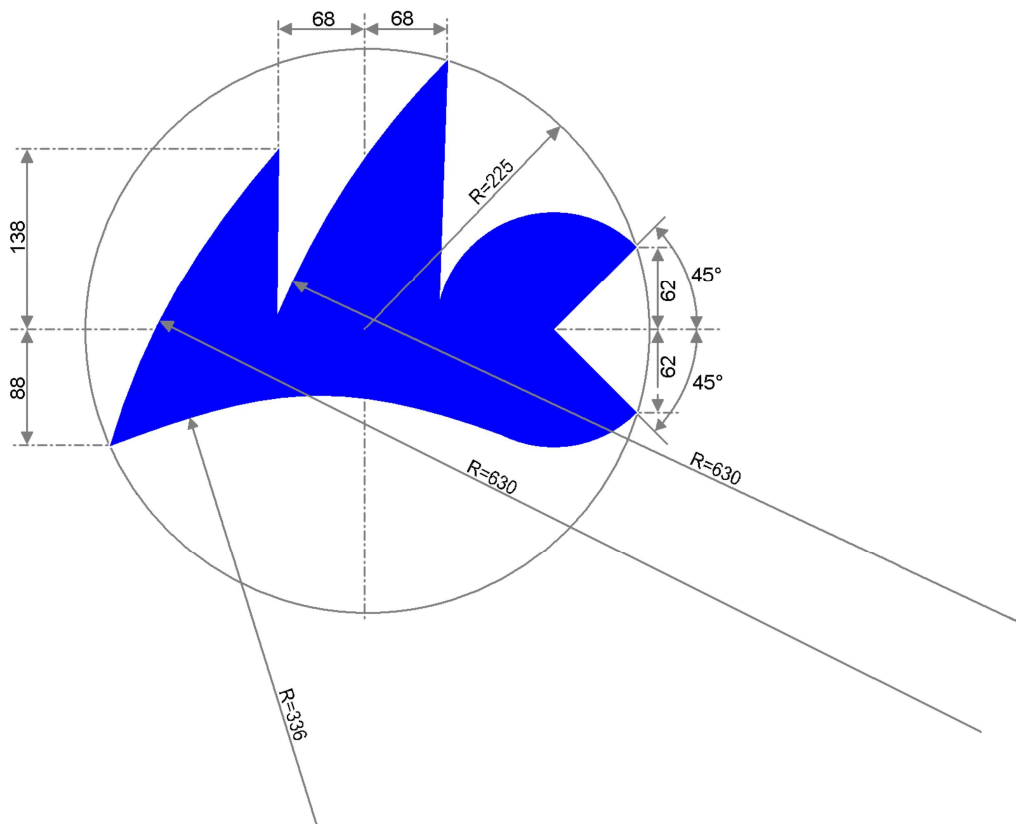

The Micro Copper Class, usually named "Micro Class" has sailed over more than 30 years, and there have been no major changes in the Measurement Rules. These were written initially in 1977, then re-written in 1988, and the English version became the official text in 1996.

The Rules were re-written for the second time in 2002, all the additions and interpretations of the previous 14 years were included in the main text, the numbering was completely different.

The present edition includes two new administrative sections, in compliance with ISAF Standard Class Rules. Appendixes 1 to 6 are to be considered as part of the Rules and are now included in the official text, approved by ISAF. All decisions and official interpretations of the previous years are incorporated in the text.

This edition of the Rules comes into effect on April 16th, 2006

Appendixes may be amended every year, this edition includes all revisions including decisions of December 2005 and January 2006, applicable from 2006, changes of December 2007 applicable from 2007, changes of February 2008, applicable from May 1st, 2008, and extension of the validity of the the test Class Rules of appendix 4, applicable from 2010.

Changes to the previous edition are marked with a black line in the left margin.

Amendments 2007 to the original edition 2006-2009 are marked with a blue line in the left margin.

Amendments 2008, including an emergency Class Rule Change to the original edition 2006-2009,

are marked with a light green line in the left margin.

Amendments 2010, extending by 3 year the validity of Test Class Rules in Appendix 4, are marked with a thick red line in the left margin.

next >>>

TABLE OF CONTENTS

Part A – ADMINISTRATION

01.00.00 – General

02.00.00 – Boat eligibility

Part B – REQUIREMENTS AND LIMITATIONS

03.00.00 – Conditions for racing

04.00.00 – Hull and Appendages

05.00.00 – Sails and Rig

06.00.00 – Stability

07.00.00 – Buoyancy

08.00.00 – Accommodations

09.00.00 – Miscellaneous

Part C – APPENDICES

Appendix A.01.00 – Production Yachts

Appendix A.02.00 – Specifications for safety material

Appendix A.03.00 – Old Rules, still applicable to some Boats

Appendix A.04.00 – Test Rules

Appendix A.05.00 – Template Measurement Certificate

Appendix A.06.00 – Recognised Class Insignia



Micro Class Rules



Part A Administration

01.00.00 General

01.01.00 Language

- 01.01.01 The official language of the Class is English and in case of dispute over translation the English text shall prevail.
- 01.01.02 The word "shall" is mandatory and the word "may" is permissive.

01.02.00 Abbreviations

ISAF	International Sailing Federation
MNA	ISAF Member National Association
IMCCA	International Micro Copper Class Association
NMCA	National Micro Class Association
ERS	Equipment Rules of Sailing
RRS	Racing Rules of Sailing

01.03.00 Authorities

- 01.03.01 **The international authority of the Class is the ISAF which shall co-operate with the IMCCA in all matters concerning these Class Rules.**
- 01.03.02 **The Certification Authority is the IMCCA which may delegate part or all of its functions to NMCA's. The IMCCA has the right to withdraw a Certificate issued by a NMCA.**

01.04.00 Administration of the Class

- 01.04.01 **ISAF has delegated its administrative functions of the class to MNA's. The MNA may delegate part or all of its functions, as stated in these Class Rules, to a NMCA.**
- 01.04.02 **In countries where there is no MNA, or the MNA does not wish to administrate the class, its administrative functions as stated in these Class Rules shall be carried out by the IMCCA which may delegate the administration to a NMCA.**

01.05.00 ISAF Rules

- 01.05.01 **These Class Rules shall be read in conjunction with the ERS.**
- 01.05.02 **Except where used in headings, when a term is printed in "bold" the definition in the ERS applies and when a term is printed in "bold italics" the definition in the RRS applies.**

01.06.00 Amendments to Class Rules

- 01.06.01 **The Class Rules are submitted to a four-yearly revision, with effect on January 1st, 2006. The present edition which include all amendments since 1977, cancel those preceding. They shall be applicable as from April 16th, 2006. Exceptionally, the next edition will be published in 2009.**
- The present revision of the edition shall be applicable as from April 16th, 2008**
- 01.06.02 **Only in exceptional cases, rules shall only be amended in this four-year period, under the form of an interpretation (see 01.07.00) or a Test Rule (see 01.06.03).**
- 01.06.03 **Test Rules**
New Class Rules may be tested for a defined period. They are published in

Appendix 4 of the Class Rules.

NMCA's may refuse application of the Test Rules for national events.

NMCA's shall require approval of the IMCCA to refuse application of the Test Rules in international events.

01.07.00 Interpretations of Class Rules

01.07.01 At any time the International Committee of the International Micro Copper Class Association shall be responsible for the interpretation of any part of these rules and it reserves the right to rule on any new eventuality that might arise.

01.07.02 Interpretations are valid for no more than four years and should be withdrawn or included in the Class Rules at their next revision.

01.07.03 A list of interpretations of these rules is published by IMCCA.

01.08.00 *(Reserved for future use)*

01.09.00 Identification on sails

01.09.01 Sail Numbers shall be issued by the MNA. The MNA may delegate issuing of Sail Numbers to the NMCA.

01.09.02 Sail numbers may be part of a list of a national handicap system.

01.09.03 A sail number is issued for a Hull and shall not be re-used for subsequent Boats.

01.10.00 Certification of Boats

01.10.01 A Measurement Certificate shall be issued by a national measurer appointed by the IMCCA or a NMCA, using the template file published by the IMCCA. This document is shown in Appendix 5.

01.10.02 The Measurement Certificate shall record the following information:

- a. **Division**
- b. **Certification Authority**
- c. **Sail Number issued by the MNA or its delegate authority**
- d. **Boat Name**
- e. **Owner**
- f. **Hull identification, including Boat type, Serial Number if any, previous known Sail Number(s).**
- g. **Builder / Manufacturer details**
- h. **Date of issue of the Certificate**
- i. **All measurements related to measurement rules, and according sketches where needed.**

01.10.03 A simplified procedure may be applied for production Boats under the terms of Appendix 1.

01.10.04 A Boat Certificate becomes invalid upon:

- a. **the change to any items recorded on the Boat Certificate as required under 01.10.02**
- b. **withdrawal by the Certification Authority**
- c. **the issue of a new Certificate**

01.10.05 Retention of Certificate documentation

The Certification Authority shall:

- a. **retain the original documentation upon which the current Certificate is based;**
- b. **upon request, transfer this documentation to the new Certification Authority if the Hull is exported.**



Micro Class Rules



02.00.00 Boat Eligibility

For a **Boat** to be eligible for racing, she shall comply with the rules in this section.

02.01.00 Class Rules and Certification

The **Boat** shall:

- a. be in compliance with the **Class Rules**;
- b. have a valid **Measurement Certificate**.

02.02.00 Class Association Markings

02.02.01 All **Mainsails** shall carry an insignia of the Micro Class (see Appendix 6, A6.01) or that of their own Class for Racers and Cruisers (see Appendix 6, A6.02). They shall also carry the sail number allotted by the MNA or NMCA (see 01.09.00).

02.02.02 Sail numbers in Spinnakers

- a. **Spinnakers are not required to carry a sail number. This changes RRS App G.1.3 (d) according to App G.5.**
- b. **If a sail number is carried, it shall be the same as on the Mainsail.**

02.02.03 All sails shall be marked with a stamp of the NMCA and relevant measurements as directed by the Technical Committee.



Micro Class Rules



Part B Requirements and Limitations

03.00.00 Conditions for racing

The **Crew** and **Boat** shall comply with the rules in Part B when racing. In case of conflict Section 3 shall prevail.

The Micro Class Rules are **Open Class Rules**, where anything not specifically prohibited is permitted.

03.01.00 Purpose

The purpose of the "Micro" Rule is to enable small sailing **Boats**, which are easily transported, to compete in elapsed time.

03.02.00 Divisions

The Micro Class includes **three Divisions of which** two divisions of production boats, Racers and Cruisers. These **two** divisions have special limitations, as defined in Appendix 1. When a **Boat** does not qualify for one of these divisions, she will be part of division "Prototype"

03.03.00 Crew number

03.03.01 **Crew** number is three. The composition of the **Crew** shall remain the same during the entire event. Only in exceptional circumstances the Jury or Race Committee shall allow a substitution of another **Crew** member.

03.03.02 **In the "Racers" and "Cruisers" Divisions and on inland lakes and waterways only, the Crew may be reduced to two members, provided the Crew number does not change during a regatta.**

03.04.00 Advertising

03.04.01 Advertising is allowed under ISAF Regulation 20 – Advertising Code in Category C.

03.04.02 National limitations on advertising are published by IMCCA.

03.05.00 Protest Flag

For international regattas like the World Championships, Euro-Micro regattas and national Open Championships, Race Committees are recommended to include following text in the Notice of Race and Sailing Instructions:
**"When protesting about an incident in the racing area, a Boat shall display the red flag as described in RRS 61.1(a).
This changes RRS 61.1(a)."**



Micro Class Rules



04.00.00 Hull and Appendages

04.01.00 Measurement Trim

04.01.01 The **Boat** shall be measured with all standing **Rigging**, running **Rigging**, deck fittings, **Rudder**, **Ballast** in their normal navigating positions.

04.01.02 Unless otherwise stated, **Centreboards** or **Daggerboards** shall be fully lowered.

04.01.03 The following shall not be on board during measurement: **Sails**, movable equipment, engine, safety and navigational equipment, personal gear, food and any kind of liquids (including fuel).

04.02.00 Hull Dimensions

04.02.01 The **Hull Length** measured at 0,70 metre above the waterline shall not exceed 5,50 metres and the average freeboard shall not be less than 0,60 metres.

04.02.02 Limitations regarding Length and Freeboard are controlled by means of templates as shown in figure 1.

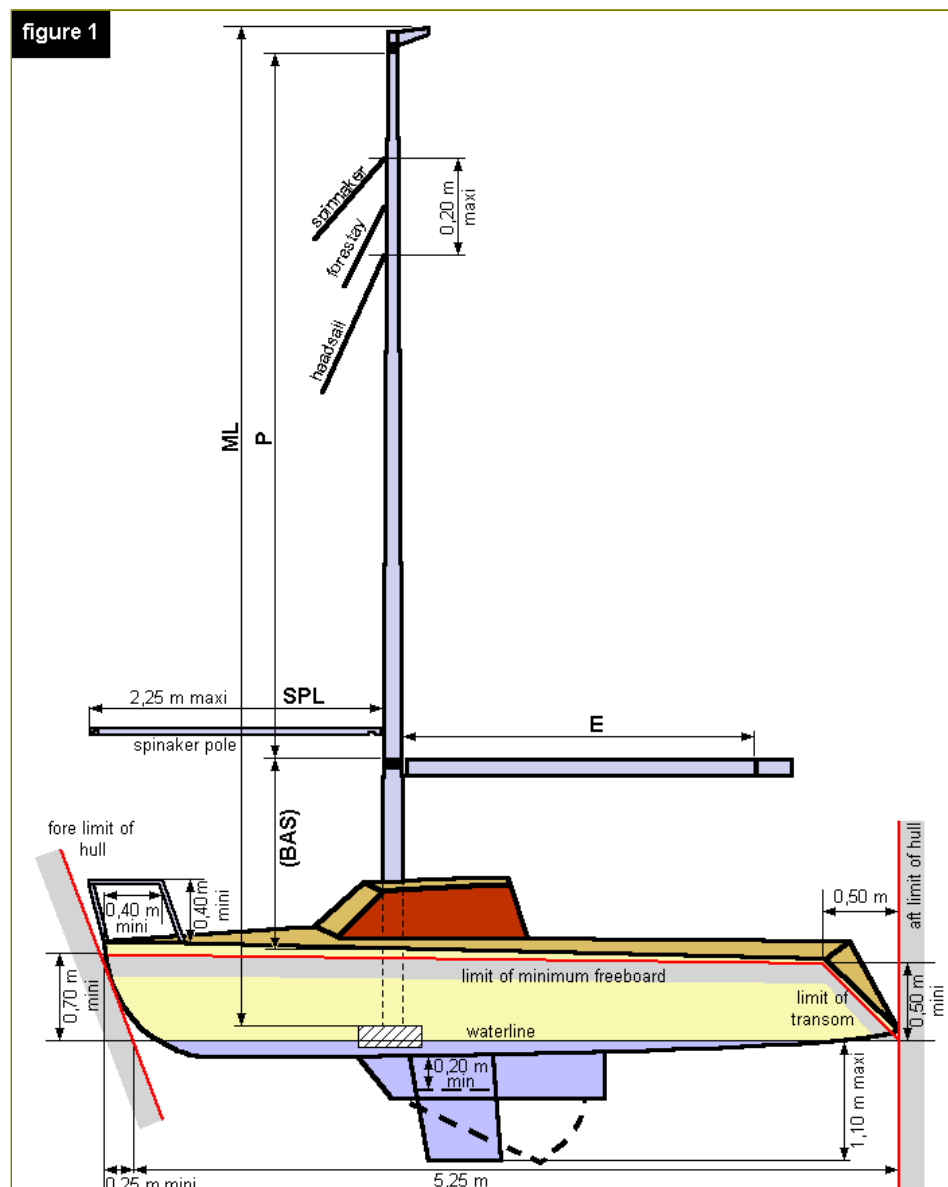

- 04.02.03 Except for a projection appearing in some types of junction between deck and **Hull** and provided the **Headsail** is tacked inside the forward limit of the template, no part of the **Hull** shall extend beyond this limit.
- 04.02.04 No part of the **Hull** shall extend beyond the aft limit of the template.

04.03.00 Boat Weight

- 04.03.01 The **Boat Weight** shall be determined by weighing.
The weight shall not be less than 450 kilograms.
- 04.03.02 The Inner **Ballast** shall be permanently secured to the structure of the **Hull**.
Ballast in moveable **Hull Appendages** is allowed as long as the **Ballast** is secured to the structure of the **Appendages** and the movement of the **Appendages** meets the stability requirements of Section 6 (06.00.00).
- 04.03.03 No material with a density greater than that of lead is allowed in any **Ballast**.

04.04.00 Maximum Beam

- 04.04.01 The Maximum Beam including plates, rubbing strakes or similar protections shall not exceed 2,45 metres.
- 04.04.02 **Outriggers** are not allowed (see RRS 50.3).

04.05.00 Maximum Draft

- 04.05.01 The Maximum Draft shall not exceed 1,10 metre in Measurement trim.
- 04.05.02 The movement of a **Centreboard** or **Daggerboard** shall be limited at the top and bottom by positive blocking devices, which shall be able to work in any circumstance.
While navigating, the blocking devices shall be fitted with a sealing system ensuring the **Boat** conforms to the **Class Rules**. The blocking device may be neutralised for trailing and transport.
- 04.05.03 The high position blocking device shall be fitted in a position ensuring that the **Boat** passes the stability tests and that there is always at least 0,20 metre protruding out of the **Hull** in the event of a capsize.
- 04.05.04 The low position blocking device shall be reliable and strong, and shall limit the movement of this **Hull Appendage** to the draft limitations of 04.05.01.

04.06.00 Rudder

- 04.06.01 Hanging **Rudders** on a transom stern are not included when measuring LOA.
Rudder's maximum projected thickness shall not exceed 40 millimetres. Its configuration shall not be a way of artificially increasing the waterline length by means of an increased stern volume.

04.07.00 Strong Construction

- 04.07.01 **Boats** shall be strongly built. It means that the **Boats** shall be able to sail in coastal waters, large bays, estuaries, lakes and rivers where conditions up to, and including, wind force 6 and significant wave heights up to, and including, 2 metres may be experienced.
- 04.07.02 There are no restrictions on construction materials.
- 04.07.03 Strongly built implies that a person weighing 80 kilograms may stand, sit or lay anywhere on the **Boat** (deck, roof, cockpit, cabin sole, berths), without having to choose the place and without causing structural failure.

04.08.00 Watertight Construction

- 04.08.01 **Boats** shall be watertight. Openings to the inner volumes, such as **under deck** spinnaker launching tubes are prohibited.
- 04.08.02 Access to the inner accommodation is permitted through a vertical opening, facing aft. This opening may be extended by a horizontal opening in front thereof.
- 04.08.03 The sill of the companionway shall be at least 0,15 metre above the cockpit sole.
- 04.08.04 **All sails and appendages shall be adjustable from the cockpit, with all hatches closed.**
- 04.08.05 **a.** Access to the cabin shall be closed and locked on request of the Race Committee.

b. If a. applies, it may only be open to extract sails or other equipment from the cabin when the boat is not tacking, gybing, hoisting, lowering, changing or reefing a sail.

- 04.08.06 The cockpit(s) shall be essentially watertight and self-draining at all angles of heel. Cockpit drains shall have a total area of no less than 10 square centimetres.
- 04.08.07 During the entire stability test as described in Section 6 (06.00.00), the companionway shall never have a clearance of less than 0,10 metre above water surface.
- 04.08.08 No opening is allowed in front of the **Mast**, except at a distance of no more than 0,10 metre from the **Mast**.
All hatches, fittings or part of the **Rig** in this area shall be tightly closed or fitted with a watertight gasket when navigating.
- 04.08.09 A hull-stepped **Mast** shall be fitted with a mast gasket.

04.09.00 Pulpit

- 04.09.01 A rigid forward pulpit securely attached shall be located near the stem.
- 04.09.02 The top of the pulpit shall be at a height of not less than 0,40 metre above the deck and shall extend aft of the foremost point of the stem by an amount of not less than 0,40 metre (see figure 1).



Micro Class Rules



05.00.00 Sail and Rig

05.01.00 General

05.01.01 As stated in ISAF Equipment Rules of Sailing (ERS) all **Sails** shall be measured on a flat surface with sufficient tension to remove wrinkles across the line of measurement and shall include the fabric length between measurement points.

Definitions of the ERS shall apply

No limit is defined for **Primary** and **Secondary Reinforcement**.

05.01.02 Only single-masted **Boats** are allowed.

05.01.03 **Double luffed Sails**, rotating **Masts**, permanently or mechanically bent **Spars** (or any similar devices) are prohibited.
Normal adjustment of **Rigging** in order to bent a **Mast** or **Spar** whilst sailing is allowed.

05.01.04 **Adjustment Eyes (formerly named Cunningham holes)** in **Headsails** and **Mainsails** are allowed.

05.01.05 a. The Maximum Sail Area upwind (**Mainsail** and **Headsail**) shall not exceed 18,50 square metres.

b. Sail Areas of a **Mainsail** or a **Headsail** shall not exceed **12 square metres**.

05.01.06 a. **RRS 50.4 shall not apply.**

b. RRS 54 shall not apply.

05.02.00 Mainsail (see figure 3).

05.02.01 Sail Area of the **Mainsail** (SMGV) is given by:

$$SMGV = P*(TW+2*MGT+3*MGU+4*MGM+4*MGL+2*E)/16$$

05.02.02 Hoist (P)

P shall be measured between the inner edges of the **Lower Limit Mark** and the **Upper Limit Mark** on the **Mast** (this changes ERS F.6). Marks are 25-millimetre **Limit Marks** painted on the **Mast**. The lower edge of the **Upper Limit Mark** corresponds to the top of the **Mainsail**. The upper edge of the **Lower Limit Mark** corresponds to a fair extension of the top of the boom in case of **Mainsails** fully secured at the **Foot**, or to a fair extension of the straight line joining the **Clew Point** to the **Tack Point** in case of loose footed **Mainsails**.

Only one pair of **Limit Marks** is allowed on a **Mast**.

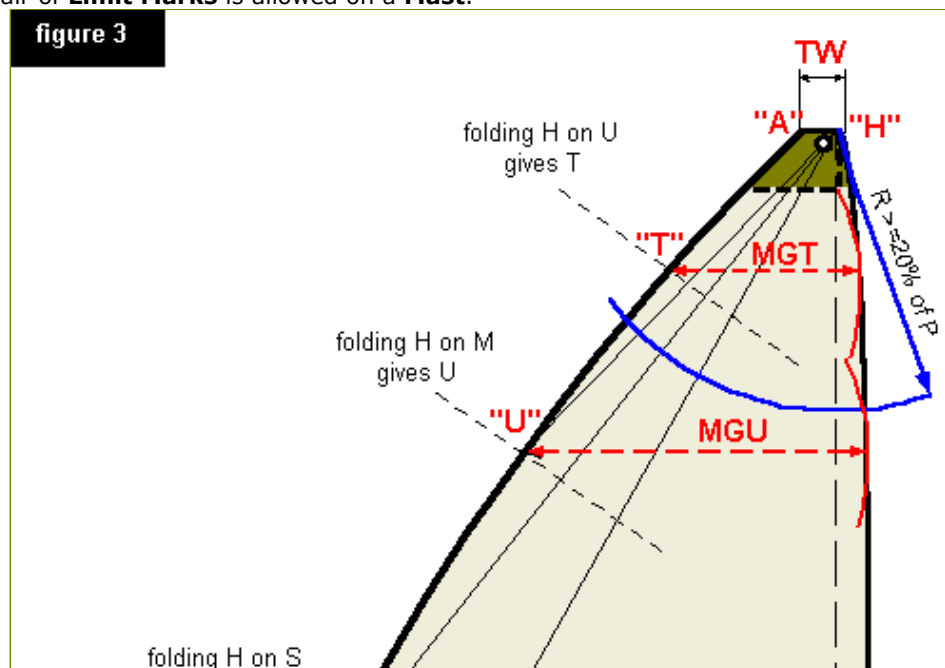

- **TW is the Top Width of the Mainsail as defined by ERS G.7.8 (see figure 4a).**

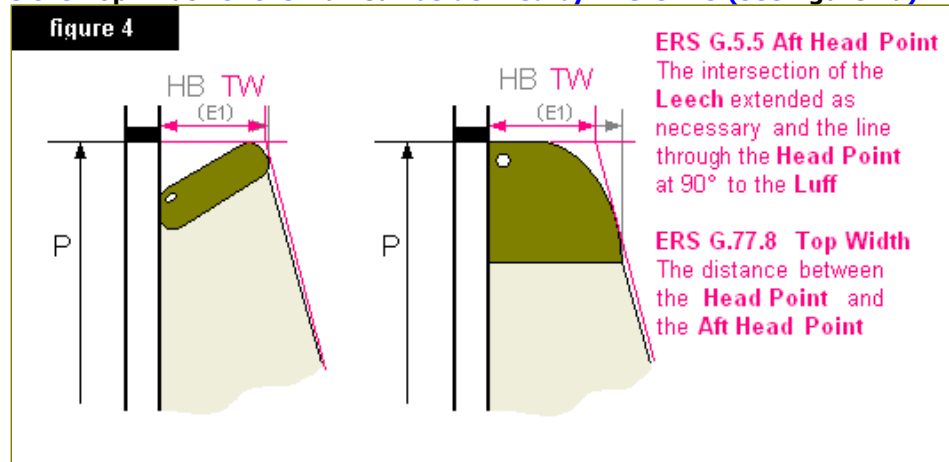

- MGL, MGM and MGU are the **Quarter Width** (ERS G.7.4), **Half Width** (ERS G.7.5) and **Three-Quarter Width** (ERS G.7.6).
MGT is the **Upper Width** (ERS G.7.7), the **Upper Leech Point** being a point, equidistant from the **Three-Quarter Leech Point** and the **Head Point** (see figure 3). All these measurement points shall be at the extreme outside of rope or fabric of the **Sail's** edge, with the **Sail** laid flat.
- E is the **Outer Point Distance** (ERS F.12.1), measured from the aft side of the **Mast** to the inner edge of a 25-millimeter measurement mark painted on the boom.

The points on the **Leech** from which the cross measurements are taken shall be determined bridging any hollows in the **Leech** with straight lines joining the aft extremities of the battens or the points at which they emerge from the fabric of the **Sail**.

When a rounded Leech allows a gain in sail area, the measurer shall extend the measurements of the nearest measurement points, in order to include the rounded Leech in the measured area.

The **Foot** roach shall not be greater than 0.15 metre. It shall be measured from the straight line joining the **Clew Point** to the **Tack Point**.

Leech Battens

The number of battens **along the Leech** of the **Mainsail** is limited to three, with following restrictions:

- The **upper Leech batten length shall not be greater than 45% E.**
- **The distance between the Head Point and the nearest point of the Top Inside Edge of the upper Leech batten pocket (BLP) shall not be less than 20% P.**
- **The medium and lowest Leech battens shall not be greater than 33% E and their position is free.**

Mainsail Heads

Any type of headboard or one head batten is allowed.

Reefing

- Reefs in the **Mainsail** are permitted along the **Foot** only.
Except for roller reefed **Mainsails**, **Mainsails** shall have at least two reefs.
The highest reef tack shall be at least 25% P above the **Tack**.
- The reefs shall be reinforced to support the same constraints as the Foot of the Mainsail. This applies to the eyes and the reinforcement cloth. They shall be of similar size, strength and dimension.**
- The Boat equipment shall include equipment, necessary to tuck the reefs up to the highest one, operational in navigation.**
The crew may be requested to demonstrate the installation of the reefs.

Old mainsails

Mainsails made according to the former Measurement Rules (edition 1988) are allowed, but they may no longer be made since January 1st, 2001, unless the **Boat** is a Racer or Cruiser and the owners association doesn't allow the **Mainsails** made in accordance with the current **Class Rules**. A copy of the 1988 rule can be found in Appendix 3.

Headsails (see figure 5).

For a test period of four years beginning January 1st, 2006, battens are allowed

according to test rules in Appendix 4 - Section 3

The test period is extended by 3 years until December 31st, 2012.

05.03.01

A **Headsail** is defined as a triangular **Sail** set in the foretriangle. **The Leech shall not extend beyond a straight line from Aft Head Point to Clew Point.**

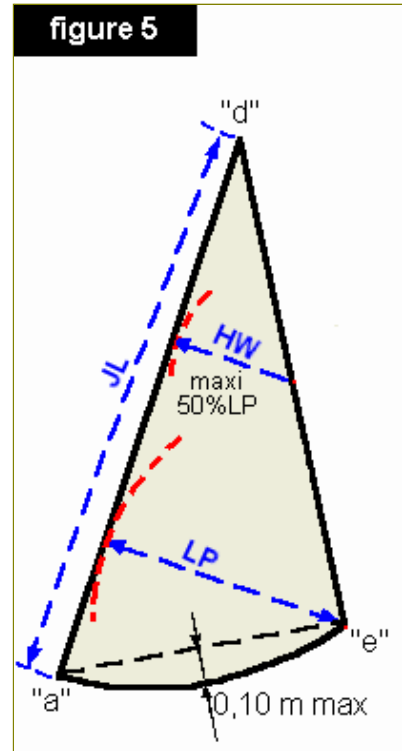

05.03.02

Where the **Top Width** is greater than 40 millimetres, the Corrected **Luff** length (JL) shall be measured between the **Tack Point** and a point where the projections of **Luff** and **Leech** is no more than 40 millimetres. Otherwise, JL is the **Luff Length**.

05.03.03

Sail area of **Headsail** (SMF) is given by:

$$SMF = 0,5 * JL * LP$$

05.03.04

The **Foot** roach shall not be greater than 0.10 metre.

05.03.05

No boards nor battens may be used in **Headsails**.

05.03.06

The area of the Storm jib shall not be greater than 3,00 square metres, nor be smaller than 2,00 square metres.

05.03.07

a. The Storm Jib shall be made of non-laminated polyester cloth (Dacron) and have a thickness of no less than 0,240 millimetre.

b. **The crew may be required to demonstrate the installation of the Storm Jib.**

05.04.00

Spinnaker (see figure 6)

05.04.01

Length of Spinnaker Leech (SL): is the distance from **Head Point** to **Clew Point**, measured along the sail's edge.

Spinnaker Half Width (SMG): is the distance between the **Half Leech Points**

Spinnaker Foot Length (SF): is the distance between the **Clew Points**

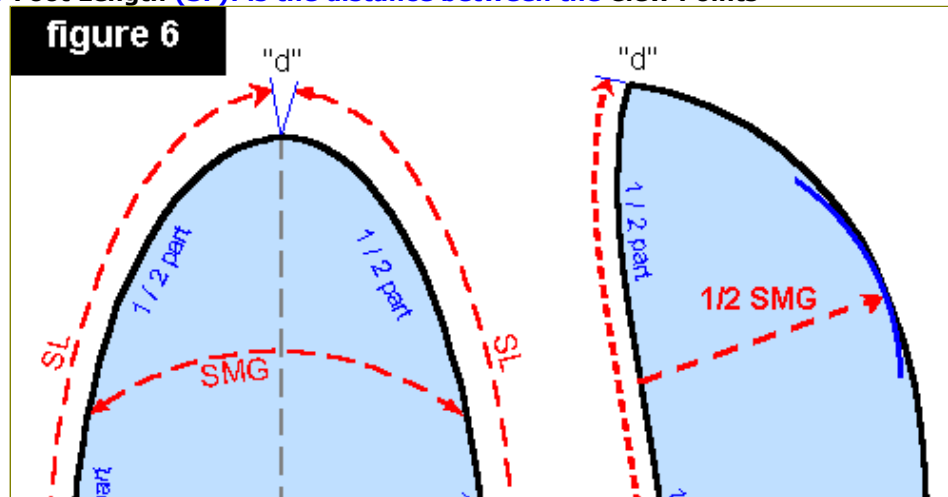

- 05.04.02 For measurement as a **Spinnaker**, a **Sail** shall have the following characteristics:
- Leeches** are of equal length.
 - The **Sail** is symmetrical about a line joining the **Head Point** to the centre of the **Foot**.
- 05.04.03 The **Half Width** (SMG) shall not be **taken as** less than 75% of the Foot Length (SF).
- 05.04.04 Sail Area of Spinnaker (SMS) is given by:

$$SMS = SL * (4 * SMG + SF) / 6$$
- 05.04.05 SMS shall not be greater than **19,60** square metres.
- 05.04.06 **The distance the Headsail halyard and the Spinnaker halyard, or between one of these halyards and the forestay Rigging Point shall not be larger than 0.20 metre. The measurement of the halyards is taken between the centrelines of the halyards, held perpendicular to the front of the Mast.**
- 05.04.07 Spinnakers made according to the former Measurement Rules (edition 2002 or earlier) are allowed, they may no longer be made since January 1st, 2005. A copy of the 2002 rule can be found in Appendix 3.**
- 05.04.08 For a test period of five years beginning January 1st, 2005, asymmetrical spinnakers are admitted according to provisional rules, published in Appendix 4 (A4.01 and A4.02). These rules may be modified yearly.**
- The test period is extended by 3 years until December 31st, 2012.**
- 05.05.00 Spinnaker Pole**
- 05.05.01 **A spare Spinnaker Pole may be carried on board and used as a replacement of a broken pole whilst racing.**
- 05.05.02 The **Spinnaker Pole** Extension (SPL) shall be measured from the forward side of the **Mast** to the extreme outboard end of the **Spinnaker Pole**, set on its fitting on the **Mast** in a horizontal position on the centre line of the **Boat**. This changes ERS F.14.1.
- An automatic Spinnaker Pole shall be set from the cockpit in its outermost position and measured with no other tension applied.**
- 05.05.03 The **Spinnaker Pole** extension (SPL) shall not be greater than 2,25 metres.
- 05.06.00 Forestay**
- A permanent forestay, **with strength no less than the Boat Weight**, is mandatory
- 05.07.00 Sail Number Limitation**
- 05.07.01 Sails aboard a yacht in a race shall be limited to not more than:
- One **Mainsail**
 - Two large **Headsails**
 - One storm jib
 - One spinnaker
- 05.07.02 Prior to a race, only one from each type of **Sails** (two large **Headsails**) shall be submitted from each **Boat** for inspection. Only **Sails** that have been stamped shall be on board.
- 05.07.03 The Storm Jib shall be on board when racing.



Micro Class Rules



06.00.00 Stability

06.01.00 Measurement Trim

For the inclining tests at small angles of heel and at 90 degrees heel, the following shall apply:

- 06.01.01 The **Boat** shall be in same Measurement Trim as for weighing (see 04.01.00).
- 06.01.02 **Centreboards** and **Daggerboards** shall be fully raised, except that **Centreboards** or **Daggerboards** designed to be permanently kept lowered and which are properly secured may be kept in such a position (see 04.05.03).
- 06.01.03 When a heavy **Hull Appendage** can move transversally, it shall be positioned in central position for the initial measurement of the stability test, and in the most unfavourable position for the measurement at low angles and at 90 degrees.
- 06.01.04 **When an inflatable floating device is used on top of the Mast, the stability tests shall be conducted with the device in position.**

06.02.00 Stability at low angles of heel

- 06.02.01 By means of a halyard or any other running **Rigging**, a pole shall be positioned athwart the **Boat** at the maximum beam station and parallel to the waterline with a weight of 20 kilograms attached to it. The distance between the **Hull** and the point of suspension of the weight shall be 2,25 metres. The test shall be carried out on both sides. The average heel angle shall not exceed 15 degrees (see figure 7)

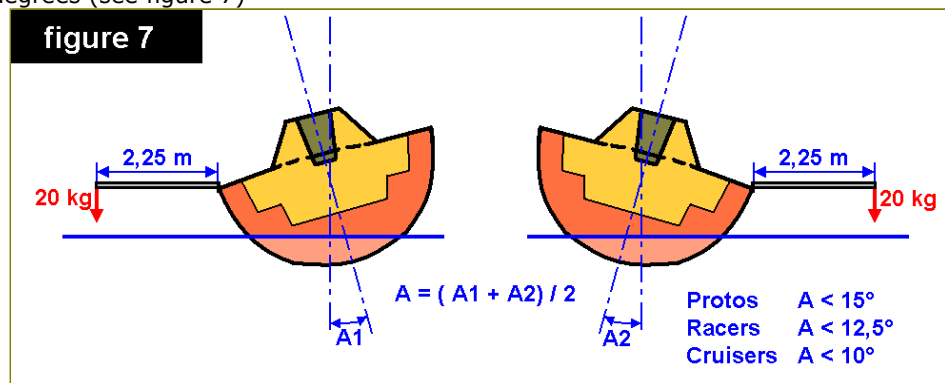

- 06.02.02 Where the maximum beam is more than 3,85 metres from the stem, the pole shall be placed at 3,85 metres.

06.03.00 Stability at 90 degrees heel

- 06.03.01 The **Boat** is pulled over until her **Sheer Line** is vertical with a weight of 10 kilograms attached as close as possible to the **Mast Head Point**. The **Boat** shall support this weight. If the angle of heel increases, she fails the test (see figure 8)

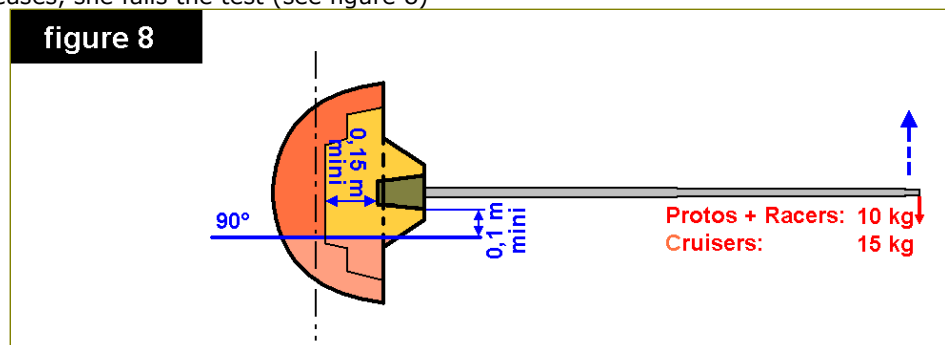

- 06.03.02 The **Boat** is pulled in position by the **Crew**, under sole responsibility of the **Skipper**.



Micro Class Rules



07.00.00 Buoyancy

- 07.01.00 The total volume, including the own volume of **Hull** and structure, measured in litres, shall be no less than the weight in measurement trim, measured in kilograms, increased by 51 kilograms.
- 07.02.00 Buoyancy volume and its repartition shall allow the **Boat** to float in upright position, with deck above the surface and sufficient stability, when totally flooded.
- 07.03.00 Additional buoyancy volumes shall be made of compact foam material (polyurethane, expanded or extruded polystyrene). They shall be secured to the **Hull** or its structure in order to avoid any move or structural failure.
Watertight volumes shall be filled with foam, as described.
Only volumes under the **Sheer** shall be considered as making part of the buoyancy volume.
Inflated volumes are prohibited.
- 07.04.00 Guidelines on buoyancy are published by IMCCA. These are not rules.



Micro Class Rules



08.00.00 Accommodations

08.01.00 Windows

One or two windows with a total area of not less than 0,05 square metres shall provide enough light to the cabin.

08.02.00 Berths

08.02.01 There shall be at least three permanent berths of not less than the following dimensions: 1,85 metres long, 0,55 metre wide at one end, 0,35 metre wide at the other end (see figure 9).

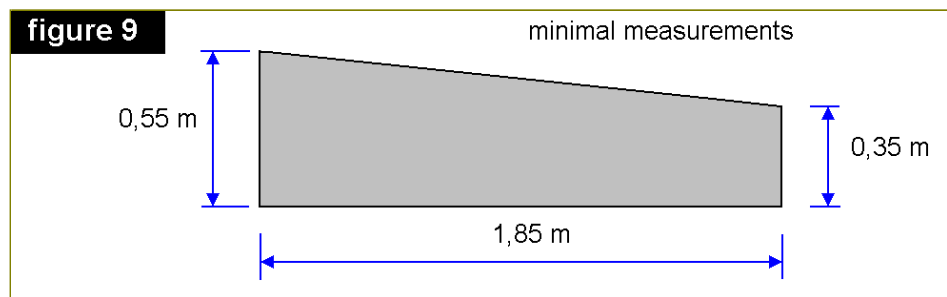

08.02.02 In case of double berths or V-berths, the width at the narrowest end can be reduced to 0,45 metre (see figure 10).

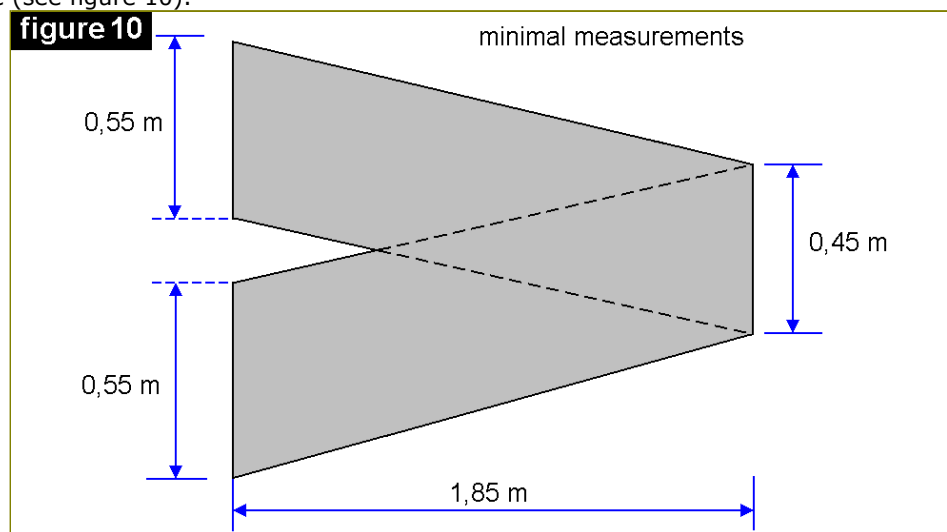

08.02.03 Over the whole area of the berth, the minimum clearance taken above the berth (without mattress) shall not be less than 0,35 metre (see figure 11).

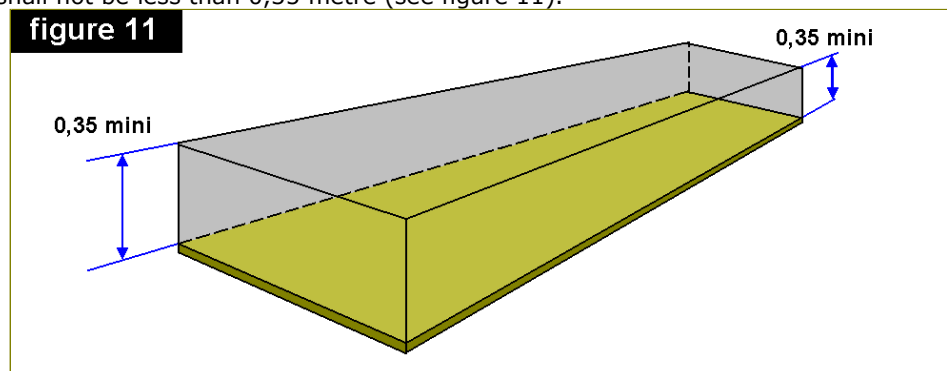

08.02.04

Each berth shall have at one end a minimum clearance of 0,85 metre over an area at least 0,40 metre long and 0,40 metre wide (see figure 12). **No adjacent cabin sole area, as described in 08.04.04, is required.**

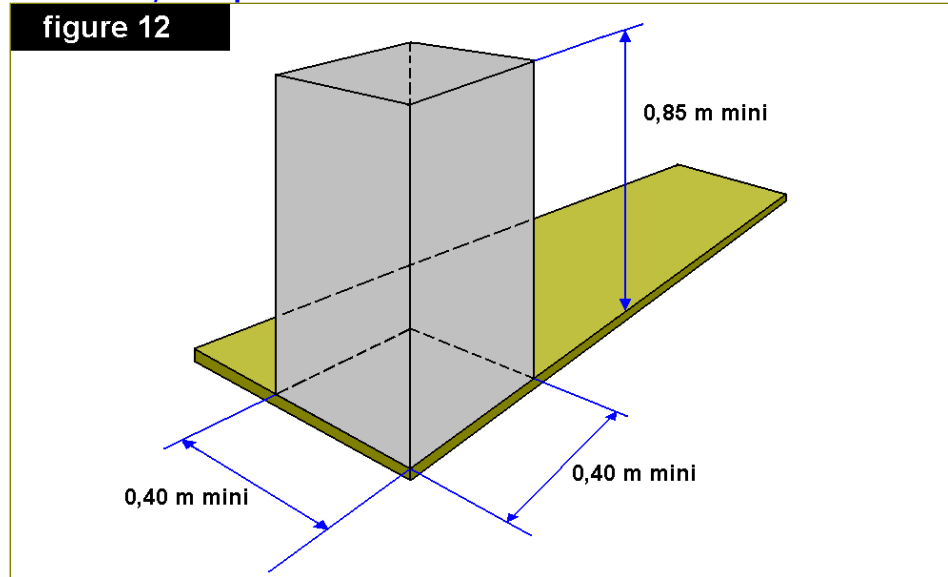

08.02.05

Clearance above the berth surface is measured vertically from a flat surface passing on the lateral structure.

08.02.06

For **Boats** built after December 31st, 2001, the fore berth(s) shall not be inclined by more than 3 degrees from horizontal.

08.03.00

Headroom

08.03.01

A minimum headroom of 1,15 metre shall be found over an unobstructed level area of cabin sole of not less than 0,30 square metre and across a minimum width of 0,30 metre, located between two berths (see figure 13).

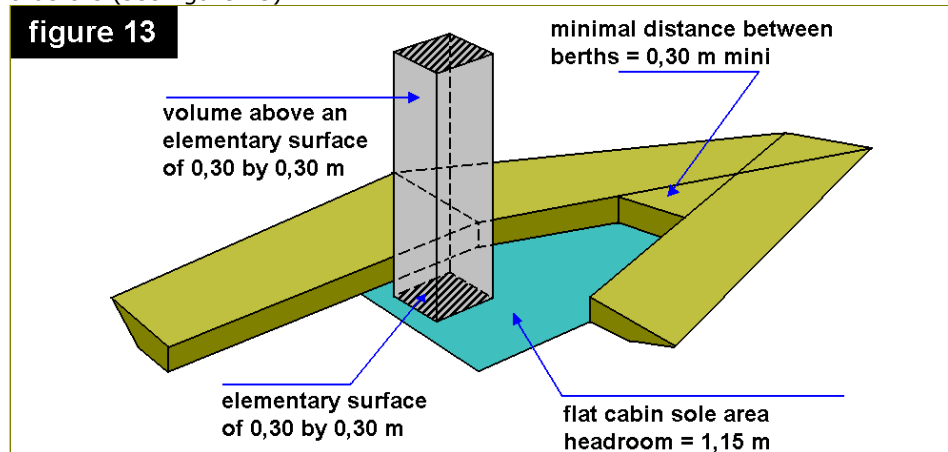

08.03.02

Where a centreboard or daggerboard case or any structure divides the qualifying area of the cabin sole for headroom, the total area shall be the sum of the elementary areas, but no area shall be considered if it doesn't include at least one square area of 0,30 by 0,30 metre (see figure 14).

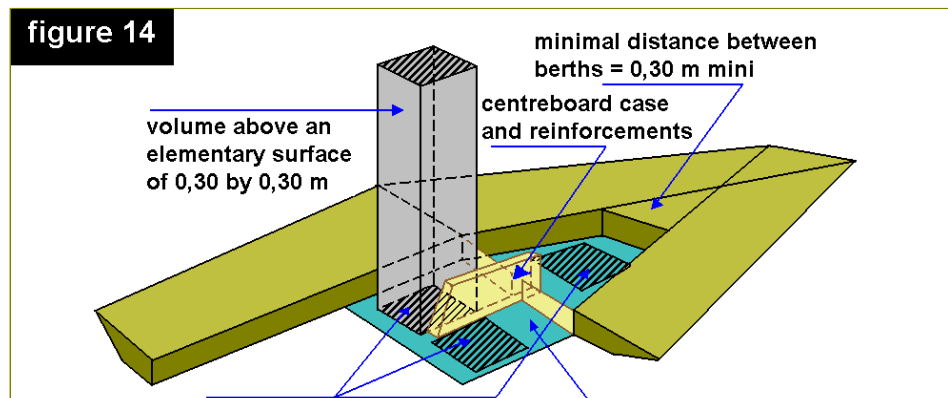

08.04.00 Sitting Area

08.04.01

In order to sit comfortably, a minimum headroom of 0,85 metre above the bottom of the berths or of a seat shall be provided across a minimal width of 0,40 metre over a minimal overall length of 1,80 metre (each element constituting this length shall be no less than 0,40 metre) and beyond the vertical faces of berth fronts (see figure 15).

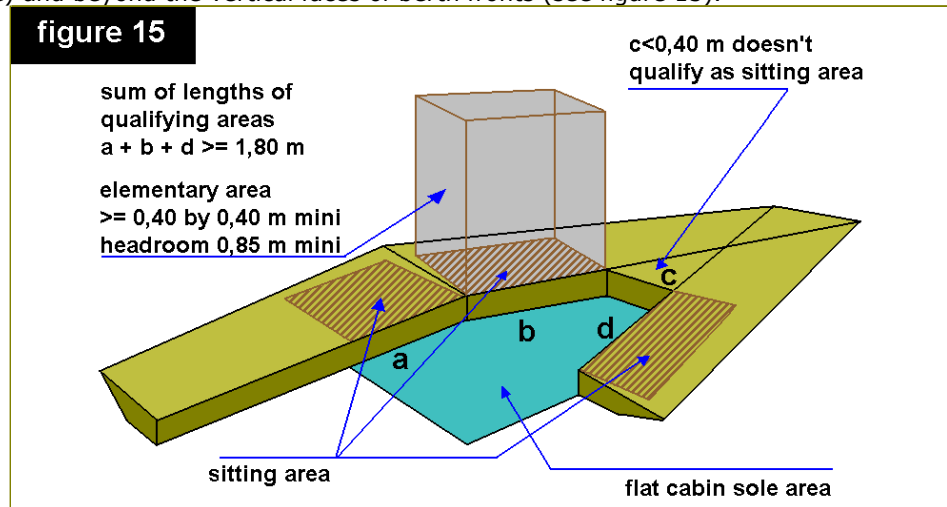

08.04.02

Sitting areas of different seats shall not overlap.

08.04.03

Sitting areas and berth area (see 08.02.01 to 08.02.06) may overlap.

08.04.04

For each element of sitting area, as described above, there shall be an adjoining element of cabin sole area of no less than 0,30 by 0,30 metres, **matching the requirements of 08.03.01**, having one side vertical on one side of qualifying sitting area (see figure 16).

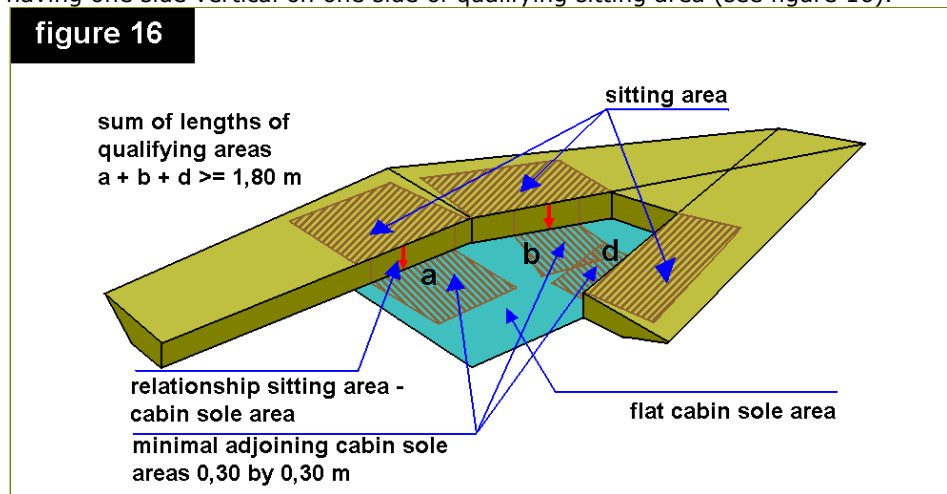

08.04.05

Cabin sole areas adjoining to different seats may overlap.

08.05.00

Grandfathering

08.05.01

Boats built prior to January 1st, 2002, but not meeting the requirements of part 8 may be granted a waiver if there is no reasonable way to modify the **Boat** to make her strictly conform to the rules.



Micro Class Rules



09.00.00 Miscellaneous

09.01.00 Crew Righting Moment

Only straps are allowed, and in the cockpit only. Any other devices such as trapeze wires are prohibited.

09.02.00 Navigation Aids

All electronic navigation aids are allowed **if they are currently available on the market at the time of purchase.**

09.03.00 Safety Equipment

09.03.01 Every **Boat** shall have aboard all the relevant safety equipment requested by local regulations.

09.03.02 The following equipment shall only be aboard even when not requested by local regulations:

- 1 lifejacket for every **Crew** member;
- 1 lifebuoy (may be of the horseshoe type);
- 1 boat hook;
- 1 stern oar or a pair of oars with rowlocks or two sculls;
- 1 bucket (10 litres minimum);
- 1 anchor or grapnel (5 kilograms minimum) with at least 5 metres of chain (diameter 6 millimetres) and at least 20 metres of cable diameter 10 millimetres;
- 1 towing rope.

09.03.03 Technical specifications of the safety equipment are to be found in Appendix 2.



Micro Class Rules



Appendix 1 – Production Boats

Revised November 2004-December 2006

Refers to Rule 07.04.03

- A1.01 To qualify as a Production Micro, **Boats** shall comply with following criterions:
- a. A reference **Boat** of the production has been declared as conform to all dispositions of the Micro Rule including all those specific to the production **Boats**, and a full Measurement **Certificate** shall be issued by a national Micro Class measurer.
 - b. A managing authority is declared. This authority may be:
 - an international Owners Association;
 - a group of national Owners Associations;
 - a national Owners association;
 - a group of national Micro Class Associations;
 - the national Micro Class Association;
 - the International Micro Copper Class Association (IMCCA).
 - c. The managing authority issues a Specifications Sheet. This reference document is made available to all measurers by IMCCA.
 - d. At least ten **Boats**, identical to the original one shall have been constructed. The national IMCCA representative or national Micro Class measurer may grant a temporary status of production **Boat** as soon as production started, provided the builder shows his intention of producing at least 10 **Boats**, and has the production capacity to do so. This status can be confirmed yearly by IMCCA as long as less than 10 **Boats** have been built.
 - e. The **Boat** of the competitor shall also be conform to the original **Boat** of the production.
- A1.02 In case of non-conformity, believed to improve the performance, the **Boat** shall be classified as a "prototype" providing she complies to all the requirements of the Micro **Class Rules**. In case of non-conformity, not believed to improve the performance, the owner may be given a reasonable delay to correct the non-conformity, if required.
- A1.03 The managing authority may wish to alter the characteristics of the production. For such modified **Boats** to qualify as a production **Boat** the following shall apply:
- a. the modification shall be approved by the National Micro Class Association, on proposal of the national measurer;
 - b. at least ten of such modified **Boats** shall have been built and sold, or a production of at least 10 **Boat** has started, according to A.01.d.
- A1.04 Due to the diversity of productions, they shall be spread among two Divisions: "Racers" and "Cruisers" in accordance with their characteristics. To be ranked in Division "Racers" or "Cruisers", the characteristics of each production shall fulfil the following requirements:

	Rule	Racer	Cruiser
Minimum Weight	04.03.01	540 kilograms	560 kilograms
Maximum Mast Length		8,20 metres	7,70 metres
Maximum length of Mainsail hoist "P"	05.02.02	7,60 metres	6,85 metres
Stability at low angles	06.02.00	12,5 degrees	10 degrees
Stability at 90°	06.03.00	10 kilograms	15 kilograms
Headroom	08.03.01	1,20 metre	1,25 metre
Mattresses on berths		3	3
Sink, cooker, storage		Recommended	Compulsory

Note: for Racers, a weight of 12 kilograms is recommended for the stability test at 90° (06.03.00).

- A1.05 For both Divisions, **Rigging** attached to the **Mast** is limited to: 1 forestay, 1 pair of shrouds, 1 pair of lower shrouds, 1 backstay.
- A1.06 For the purpose of **Mainsail** measurement and calculation, the values of mainsail hoist "P" and

Outer Point Distance "E" shall be exactly the values measured on the reference **Boat**.

- A1.07 The **IMCCA Technical Committee**, each year, the list of production **Boat types** qualifying under Division "Racers" or "Cruisers" after proposal by **the NMCA's**.
- A1.08 Micro **Boats** built in a production of more than 50 boats on January 1st, 1988 and ratified as "Racer" class or "Cruiser" class shall be maintained so, even if one of their characteristics, being hard to modify, should not conform to the new regulations.
- A1.09 Building of a production **Boat** by an individual is permitted, if the plans are published, available on the market, and a production of at least 10 **Boats** is intended.
- A1.10 If the production is already ratified, building by individuals shall be authorised by the managing authority. **Boats** having been built that way shall be strictly conform with the characteristics and prescriptions of the managing authority, and shall obtain a measurement **Certificate** issued by the official measurer of its national Micro Class association.
- A1.11 For new productions, scheduled to be built by individuals, a detailed plan shall be submitted to the National Micro Class association, which will measure the first **Boat** built, and establish a Specifications Sheet, specifying particularly the Division together with a measurement form attesting the conformity of each **Boat**.
- A1.12 Buoyancy
 - a. All production **Boats** from commercial manufacturers built after December 31st, 2004 shall have the buoyancy installed by the manufacturer and controlled on the Reference **Boat** by a national measurer before being granted the status of production **Boat**.
 - b. For some old **Boats** in "Cruiser" and "Racer" Divisions, the required buoyancy cannot be reached according to Section 7 (07.00.00). Inflatable buoyancy volumes may be accepted provided they are installed as mentioned on the Measurement **Certificate** of the Reference **Boat**. This should ensure the **Boat** floats in a normal position when flooded.



Micro Class Rules



Appendix 2 – Specifications for Safety Material

Refers to 09.03.03

A2.01 **Boat Hook**

The boat hook is a safety device on its own and shall not be combined with another piece of safety equipment required by the measurement rule. The length shall be no less than 1,10 metre. The handle shall be rigid, made of wood or metal and its diameter shall not be less than 20 millimetres. The hook shall be able to catch a tube of a diameter of 30 millimetres.

A2.02 **Paddles or Oars**

The paddles or oars shall have a length of no less than 1,20 metre and the propulsive area shall be no less than 0,15 by 0,30 metre. The handle shall be rigid, made of wood or metal, and its diameter shall not be less than 20 millimetres.

A2.03 **10 Litres Bucket**

The bucket shall have a circular cross-section and shall be fitted with a solid handle and a rope of no less than 1,50 metre.

A2.04 **Towing System**

The towing system includes a towing rope and securing points on the **Boat**.

a. Towing rope:

- Length no less than 10 metres.
- Diameter no less than 10 millimetre.
- Specific gravity no more than water.

b. Position of securing points:

- Shall not be out of reach of the **Crew**.
- One point in the first 20% of the **Hull Length**
- Two points in the last 20% of the **Hull Length**, placed symmetrically on both sides and no less than 0,80 metre from each other

c. Specifications of securing points:

- May be cleats, bollards or eyes.
- Cleats shall be 150 millimetres long and 20 millimetres wide.
- Eyes shall be stainless steel, section no less than 6 millimetres, inner diameter no less than 20 millimetres.

d. Minimum load:

Any of the securing points shall resist a load of no less than 1500 kilograms.



Micro Class Rules



Appendix 3 – Old Rules still applicable to some boats

A3.01.00 Mainsails

Refers to Rule **05.02.09** - replace existing 05.02.00 by:

A3.01.01 Sail Area of the mainsail (SMGV) is given by:

$$SMGV = P * 0,25 * (0,5 * E1 + E2 + E3 + E4 + 0,5 * E5)$$

A3.01.02 Hoist (P)
 P shall be measured between the inner edges of two "one-inch" **Limit Marks** positioned on the **Mast**. The lower edge of the upper mark corresponds to the top of the **Mainsail** headboard. The upper edge of the lower mark corresponds to a fair extension of the top of the boom in case of **Mainsails** fully secured at the **Foot**, or to a fair extension of the straight line joining the **Clew Point** to the **Tack Point** in case of loose footed **Mainsails**.

A3.01.03 Widths

- E1 shall be the Maximum fore and aft dimension of the top of the **Mainsail**.
- E2, E3 and E4 shall be the **Three-Quarter Width, Half Width and Quarter Width** (see figure 3a).
- E5 is the **Outer Point Distance** (ERS F.12.1), mesured from the aft side of the **Mast** to the inner edge of a 25-millimeter measurement mark painted on the boom.

All measurement points shall be at the extreme outside of rope or fabric of the **Sail's** edge, with the **Sail** laid flat.

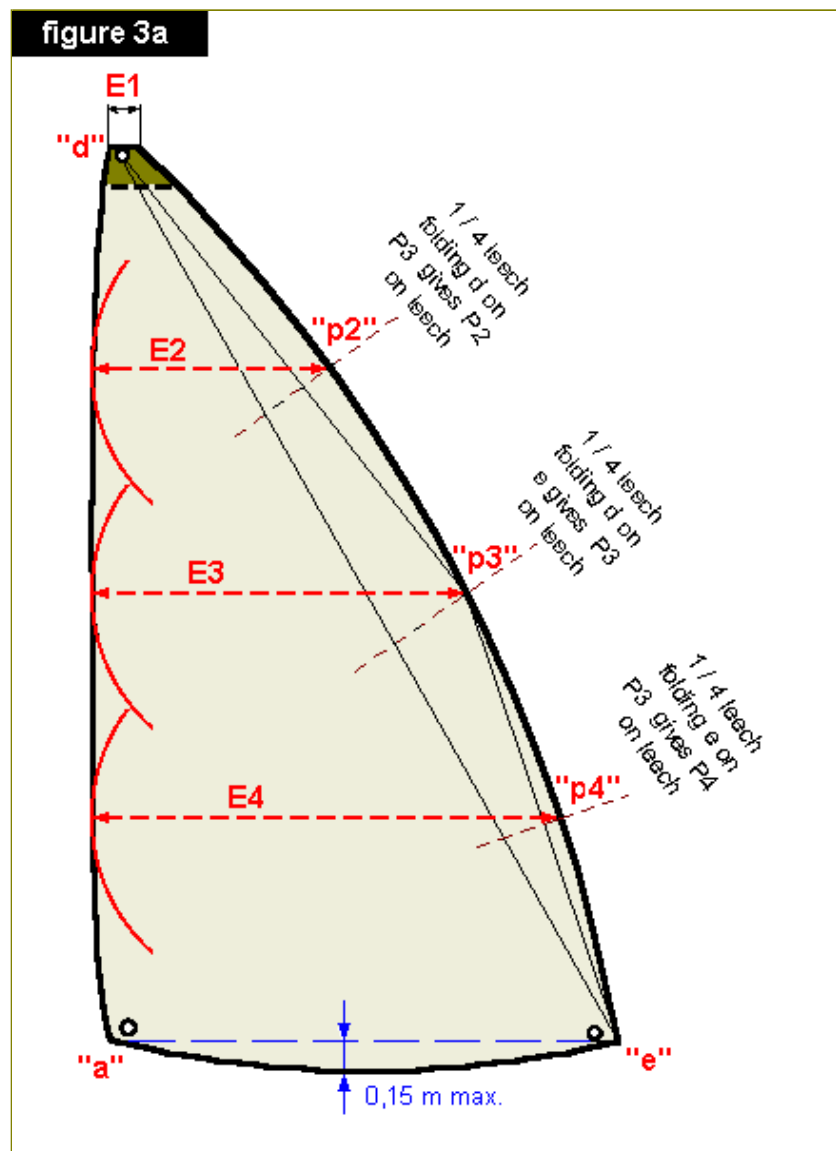

A3.01.04 The points on the **Leech** from which the cross measurements are taken shall be determined bridging any hollows in the **Leech** with straight lines joining the aft extremities of the battens or the points at which they emerge from the fabric of the sail.

A3.01.05 The foot roach shall not be greater than 0,15 metre. It shall be measured from the straight line joining the **Clew Point** to the **Tack Point**.

A3.01.06 Battens
The number of battens in the **Mainsail** shall be limited to three. The batten length shall not be greater than 0,25* the boom **Outer Point Distance** (see ERS F.12.1).

A3.02.00 Spinnakers

Refers to Rule 05.04.08 - replace existing 05.04.04 and 05.04.05 by:

A3.02.01 Sail Area of Spinnaker (SMS) is given by:
$$SMS = 0,41 * SL * (SMG + SF)$$

A3.02.02 SMS shall not be greater than 18,50 square metres.



Micro Class Rules



Appendix 4 – Test Rules

these rules are in a test period and may be modified yearly. IMCCA is not responsible for sails becoming obsolete due to a change of test rules.

A4.01.00 Asymmetrical Spinnakers

(05.04.00) *Refers to Class Rule 05.04.00*

This rule was introduced in 2005 for a test period of 5 years extended by 3 years in 2010, ending on December 31st, 2012

A4.01.01 Asymmetrical spinnakers are only allowed in Divisions "Racers" and "Cruisers".

A4.01.02 a. Spinnaker **Luff** (SLu): is the distance from **Head Point** to **Tack Point**.

(05.04.01)

b. Spinnaker **Leech** (SLe): is the distance from **Head Point** to **Clew Point**.

c. Spinnaker **Half Width** (SMG): is the distance between the **Half Luff Point**, equidistant between the **Tack Point** and the **Head Point**, and the **Half Leech Point**.

d. Spinnaker **Foot Length** (SF): is the distance from **Tack Point** to **Clew Point**, measured on a straight line.

A4.01.03 The **Half Width** (SMG) shall not be taken as less than 75% of the Spinnaker **Foot Length** (SF).

(05.04.03)

A4.01.04 The **Foot Length** (SF) shall not be taken as less than 1.5*STL (Bowsprit End Distance, see A4.02.02.b), and the **Half Width** (SMG) shall not be taken as less than 1.125*STL.

NEW

A4.01.05 Sail Area of Asymmetrical Spinnaker (SMAS) is given by:

(05.04.04)

$$SMAS = (SLu+SLe)*(4*SMG+SF)/12$$

A4.01.06 SMAS shall not be greater than 19.60 square metres.

(05.04.05)

A4.02.00 Spinnaker Poles and Bowsprits

(05.05.00) *Refers to Class Rule 05.05.00*

This rule was introduced in 2005 for a test period of 5 years extended by 3 years in 2010, ending on December 31st, 2012

A4.02.01 A spare **Spinnaker Pole** or **Bowsprit** may be carried on board and used for replacement of a broken **Spinnaker Pole** or **Bowsprit** whilst racing.

(05.05.01)

A4.02.02 a. The **Spinnaker Pole** Extension (SPL) shall be measured from the forward side of the **Mast** to the extreme outboard end of the **Spinnaker Pole**, set on its fitting on the **Mast** in a horizontal position on the centre line of the **Boat**. This changes ERS F.14.1.

(05.05.02)

An automatic Spinnaker Pole shall be set from the cockpit in its outermost position and measured with no other tension applied.

b. The Bowsprit End Distance (STL) is the distance measured from the forward side of the **Mast** to the forward end of the **Bowsprit**.

c. **When not used for setting an asymmetrical spinnaker, a Bowsprit shall be retracted within the limits of the Hull template (see figure 1).**

A4.02.03 a. The **Spinnaker Pole** Extension (SPL) shall not be greater than 2.25 metres.

(05.05.03)

b. When the **Bowsprit** End Distance exceeds 2/3 of Spinnaker **Foot Length** (SF), 1.5* the value of STL shall be used as SF for Spinnaker Area calculation.

c. When the **Bowsprit** End Distance exceeds 8/9 of Spinnaker **Half Width** (SMG), 1.125* the value of STL shall be used as SMG for Spinnaker Area calculation.

A4.03.00 Headsails

(05.03.00) *Refers to Class Rule 05.03.05*

This rule was introduced in 2005 for a test period of 4 years It was modified in 2008 to apply until end of 2009.

This rule is extended by 3 years in 2010, ending on December 31st, 2012

A4.03.01
 (replace
 05.03.05 by
 text:)

No board is allowed in **Headsails**. No more than two battens of any size are allowed in **Headsails** except the Storm Jib, if the top inside edges of the **Batten Pockets** are totally within 20% of LP from the **Leech**. The top inside edge of the top **Batten Pocket** shall not be less than 30% of the **Luff Length** from the **Head Point**.

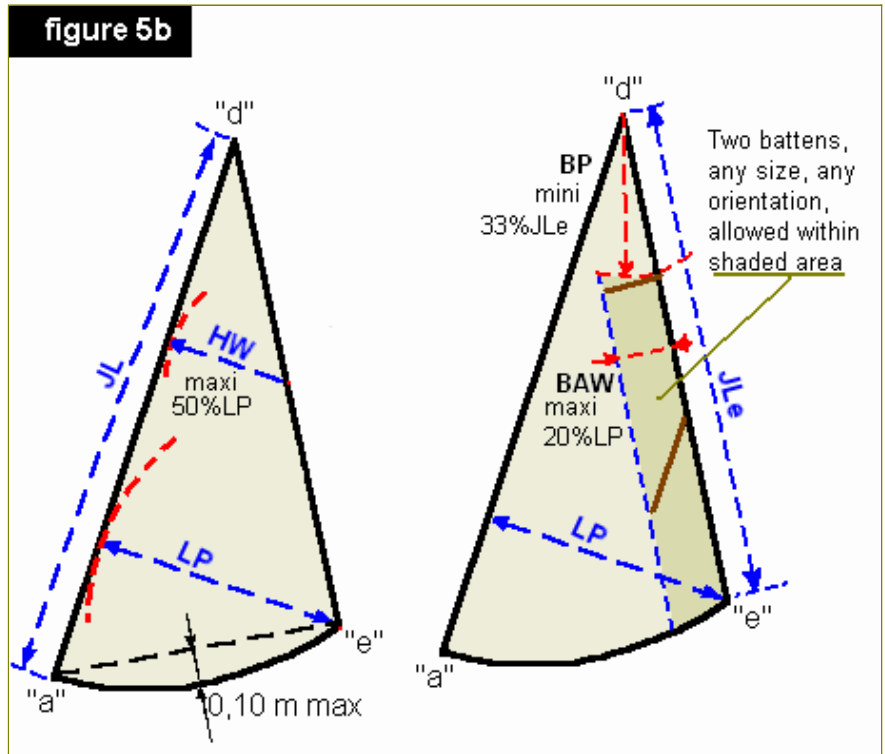



Micro Class Rules



Appendix 5 – Measurement Certificates

Refers to Rules 01.10.00 and 02.01.00

The measurement sheet was introduced in 2002 and is made mandatory by the present edition of the Class Rules. Measurers and Race Committees shall give the competitors a reasonable delay to have their boats measured. No delay is given to new boats and reference boats of new productions.

E	I.M.C.C.A.					
MICRO MEASUREMENT CERTIFICATE						
Part 1 - HULL - SAFETY - ACCOMMODATION - CENTERBOARD						
Div :	Proto	NAT	Number			
Owner:						
Name:		Chr Name:		Phone:		
Address:						
Zip Code:		City:				
Boat:						
Name:		Type:		Designer:		
Builder :		Reference SailNr:				
A	HULL DATA					
Item	ARTICLES	DESCRIPTION OF RESTRICTIONS	RESTRICTIONS	Measured	Measurer's Comments:	
01	04.03.00	Boat Weight	450 kg			
02		Centerboard Weight	NONE			
03	04.04.00	Maximum Beam	2,45 m maxi			
04	04.05.00	Draught	1,10 m maxi			
05	04.06.00	Rudder Thickness	0,040 m max			
	04.02.00	Hull Dimensions				
06		Length Over All - (h=0,70m)	5,50 m maxi			
07		Length Waterline	5,25 m maxi			
08		Freeboard at stem	0,70 m mini			
09		Freeboard at 5 m from stem	0,50 m mini			
	06.02.00	Stability at Low Angles	<= 15°			
10		A = (A1 + A2) / 2	A1 =			
11			A2 =			
12	06.03.00	Stability at 90°	positive			
13	04.08.07	Freeboard at 90°	0,10 m mini			
14	04.07.00	Strong Construction	YES/NO			
15	04.08.00	Watertight Construction	YES/NO			
	05.00.00	Buoyancy	Mini 501 Lt			
16		Repartition of Buoyancy	Volume	Fore-and aft	transversal	Ref waterline
17		Hull volume				
18		Fore berths				
19		Aft berths				
20		Sitting Area				
21		Other				
22	04.08.06	Cockpit : Selfdraining	YES/NO			
23	04.08.03	Height of companionway sill	0,15 m mini			
24	04.09.01	Stem Pulpit	Rigid	YES/NO		
25			Solid	YES/NO		
26		Length from stem	0,40 m mini			
27		Height	0,40 m mini			
28	Measurer's Comments:			Measurers visa: Name and date:		

B SAFETY					
Item	ARTICLES	DESCRIPTION OF RESTRICTIONS	RESTRICTIONS	yes/no	Measurer's Comments:
	07.03.02	Compulsory Material			
29		Life Jackets	3		
30		Horseshoe or round lifebuoy	1		
31	A.02.02	Oar(s) with rowlocks or Paddles	1 set		
32	A.02.01	Boat Hook	1		
33	A.02.03	Bucket 10 litres mini	1		
34		Anchor or grapnel 5 kg mini	1		
35		Steel Chain 6 mm dia - 5 m length mini			
36		fitted with line 10 mm - 20 m length mini	1		
37		Towing Rope	1		
38	A.02.04	Towing system	3 points		
39	04.05.03	Centreboard extension in high position	0,20 m mini		
C ACCOMMODATIONS					
Item	ARTICLES	DESCRIPTION OF RESTRICTIONS	RESTRICTIONS	Measured	
	08.01.01	Portlight Area	5,00 dm ² mini	Measured Area	
		location:	form:	area:	number:
40		roof			
41		hatch			
42		door			
43		cockpit			
44		hull			
	08.02.00	Berths measurement		berth 1	berth 2 berth 3
46	08.02.01	length	1,85 m mini		
47	08.02.01	head width	0,55 m mini		
48	08.02.01	foot width	0,35 m mini		
49	08.02.02	foot width double berth	0,45 m mini		
50	08.02.03	Headroom above berth	0,35 m mini		
51	08.02.04	Headroom above berth head	0,85 m mini		
	08.03.00	Cabin Sole		Measured	Measurer's Comments:
52	08.03.01	Headroom	1,15 m mini		
53	08.03.01	Cabin sole area	0,30 m ² mini		
54	08.03.01	Cabin sole area width	0,30 m mini		
	08.04.00	Sitting area measurement		Measured	Measurer's Comments:
55	08.04.01	total length	1,80 m mini		
56	08.04.01	width	0,40 m mini		
57	08.04.01	headroom	0,85 m mini		
58	08.04.04	Adjoining element of cabin sole area	YES/NO		
59	INFO	Height sitting area/cabin sole			
60	Measurer's Comments:			Measurers visa: Name and date:	

D LOCATION OF MEASURED ITEMS (INSIDE)	
61	<p>Sketch 1 Location of accommodations, sitting area, cabin sole area</p> <p>1 - centreboard case 2 - cabin sole area 3 - berths 4 - berth heads 5 - sitting area $a + b + c + d = m$</p>
62	<p>Sketch 2 Location of ballast and buoyancy</p> <p>6 - buoyancy volumes (give volume (Lt), distance from stem, distance from centreline, distance from waterline) 7 - ballast - declared weight(s) (in kg) 8 - mast foot position</p>

E		LOCATION OF MEASURED ITEMS (OUTSIDE)	
64	Sketch 3 Deck lay-out	9 - roof 10 - cockpit 11 - companionway 12 - portlights	
65	Sketch 3 Plan of the centreboard	Description of HIGH positive blocking device Description of LOW positive blocking device	
66	Measurer's Comments:	Measurers visa: Name and date:	

E	PROTO Nr	NAT	Number
MICRO MEASUREMENT CERTIFICATE			

H HEADSAILS MEASUREMENT						
Item	ARTICLES	Genua		Genua Nr		
121	05.03.03	Area Genua	SMG	12,00m² maxi		
122	05.03.02	Luff Length Genua	JLG			
123	A4.03.01	Leech Length Genua	JLeG			
124	05.03.01	Longest Perpendicular Genua	LPG			
125	05.03.01	Half Width Genua	HWG	Max 50% LP		
126	05.03.04	Foot Roach Genua		0,100 m maxi		
127	05.03.05	Boards	YES/NO	NO		
128	A4.03.01	Batten Area Width	BPG			
129	05.03.07	Top Batten Position	BAWG	20% LP		
	ARTICLES	Jib		Jib Nr		
130	05.03.03	Area Jib	SMF	12,00m² maxi		
131	05.03.02	Luff Length Jib	JLF			
132	A4.03.01	Leech Length Genua	JLeJ			
133	05.03.01	Longest Perpendicular Jib	LPF			
134	05.03.01	Half Width Jib	HWF	Max 50% LP		
135	05.03.04	Foot Roach Jib		0,100 m maxi		
136	05.03.05	Boards	YES/NO	NO		
137	A4.03.01	Batten Area Width	BPG			
138	05.03.07	Batten Area Width	BAWJ	20% LP		
	ARTICLES	Storm Jib		Storm Jib Nr		
139	05.03.03	Area Storm Jib	SMT	2,00-3,00 m²		
140	05.03.02	Luff Length Storm Jib	JLT			
141	05.03.01	Longest Perpendicular Storm Jib	LPT			
142	05.03.01	Half Width Storm Jib	HWT	Max 50% LP		
143	05.03.04	Foot Roach Storm Jib		0,100 m maxi		
144	05.03.07	Cloth Thickness Storm Jib		0,240 mm mini		



Micro Class Rules



Appendix 6 – Recognised Class Insignia Refers to 02.02.01

A6.01.00 MICRO CLASS (generic)

A6.01.01 Colour: any, but usually red, blue or black.



A6.01.02 Detail of design

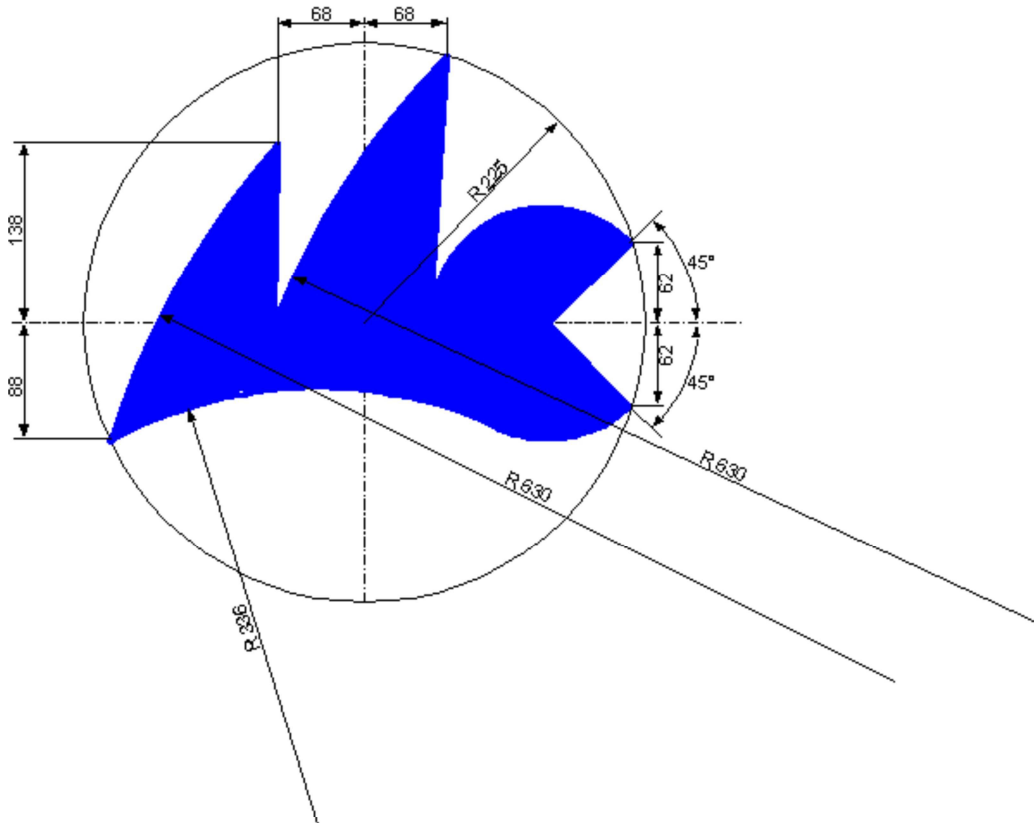

A6.02.00 Production Classes Insignia

A6.02.01 **CORSAIRE**



A6.02.02 FIRST 18



A6.02.03 **GEM**



A6.02.04 GEM (Australia)



A6.02.05 **MICROSAIL**



A6.02.06 **MICROSAIL** (old)



A6.02.07 **SAILART**



A6.02.08 **SWIFT 18**

